

SISTEMA DE REPRESENTACIÓN

APUNTES REALIZADOS POR ANTONIO CUESTA

REPRESENTACIÓN DE LAS CARAS DE UN SÓLIDO Y SU DISPOSICIÓN EN EL PLANO.

Las proyecciones o vistas de un sólido o pieza son las distintas imágenes que se obtienen al mirarla desde arriba, de frente y desde un costado, o bien el resultado de proyectar la pieza perpendicularmente sobre planos que son paralelos a sus caras, siendo sus vistas de 6.

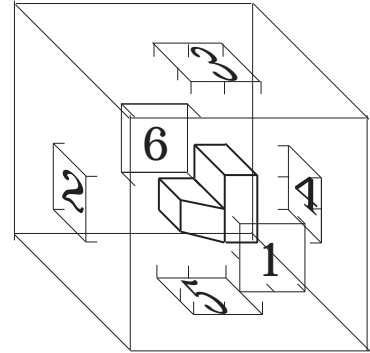

Para ello se normalizan dos sistemas:

- A) Sistema Europeo, que es el utilizado en el mayor parte de Europa.
- B) Sistema Americano, que es el utilizado preferentemente en los países de habla Inglesa.

Tanto el S. Europeo y el S. Americano consisten en representar una pieza tridimensional por medio de sus vistas en dos dimensiones. Sus disposiciones vienen establecidas por la normalización de estos dos sistemas, ya que tiene que colocarse de forma que sus dimensiones generales (altura, anchura y profundidad) queden reflejadas y relacionadas entre sí con respecto a las vistas.

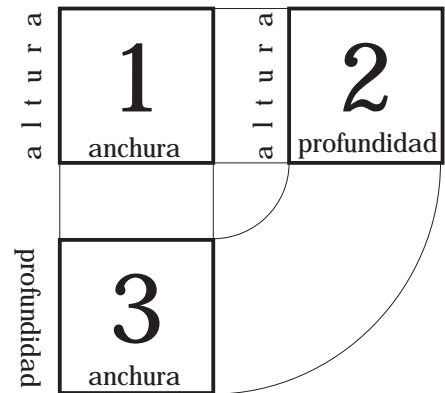

SISTEMA EUROPEO

Este sistema hace que la planta que debajo del alzado, el perfil derecho se coloca a la izquierda del alzado y el perfil izquierdo se coloca a la derecha del alzado.

El símbolo de identificación de un dibujo hecho en el Sistema Europeo es el siguiente:

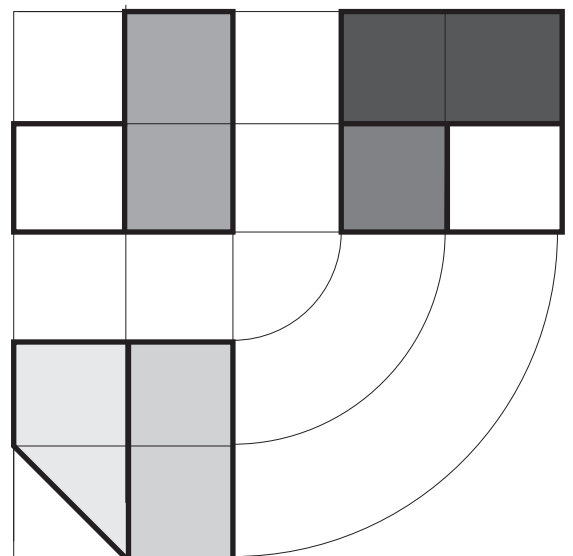
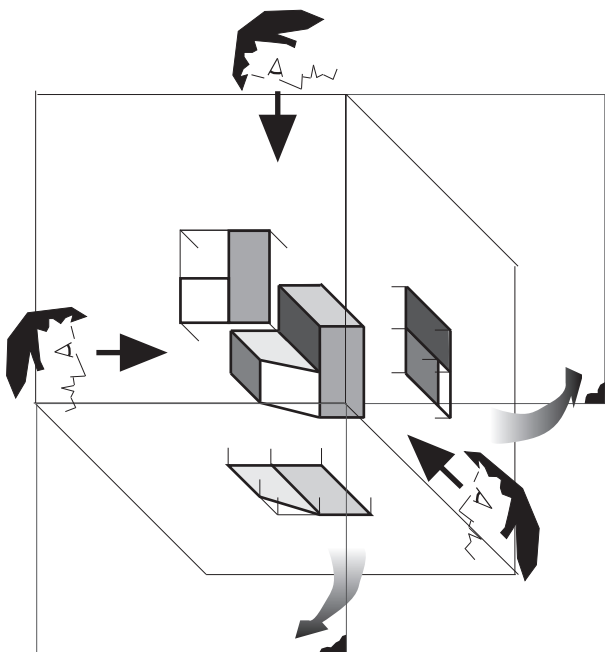
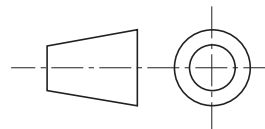

REPRESENTACIÓN DE LAS CARAS DE UN SÓLIDO Y SU DISPOSICIÓN EN EL PLANO EN SISTEMA EUROPEO.

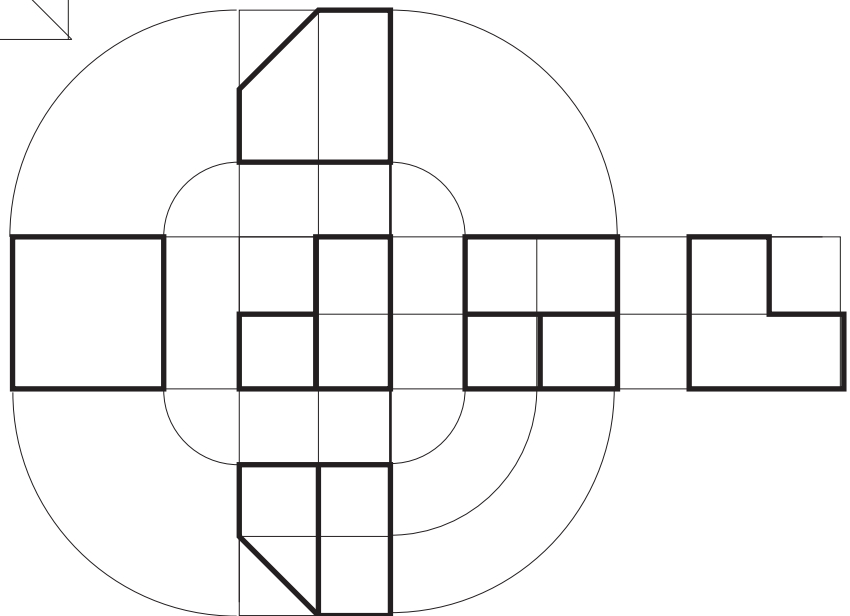
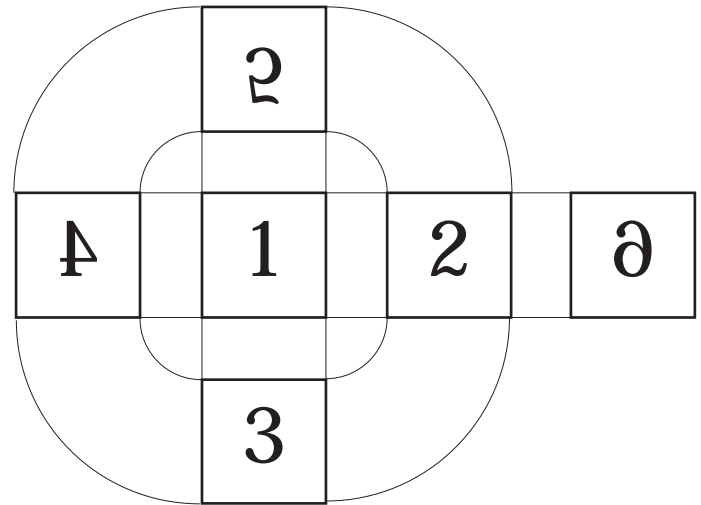
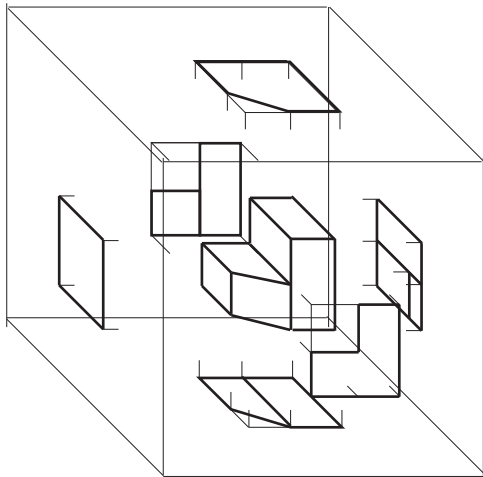
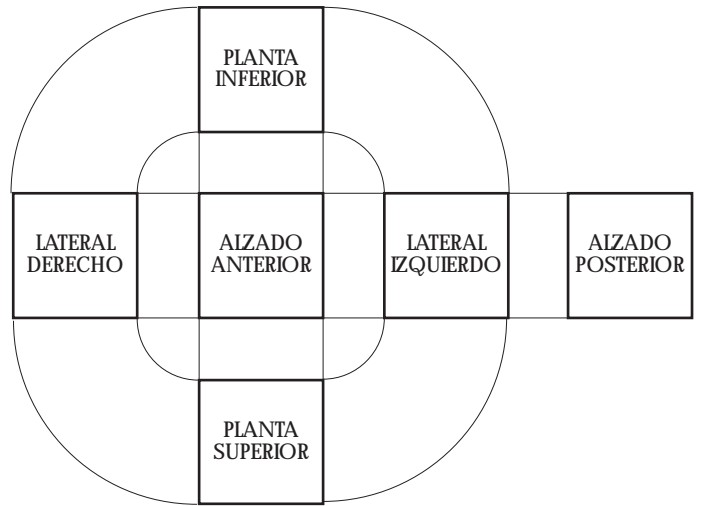
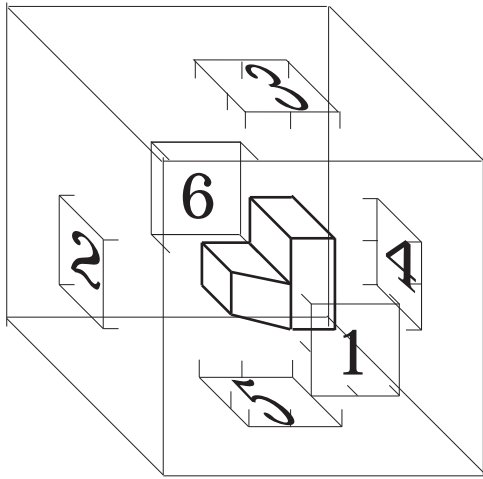

S I S T E M A A M E R I C A N O

Este sistema hace que la planta quede encima del alzado, el perfil derecho se coloca a la derecha del alzado

El símbolo de identificación de un dibujo hecho en el Sistema Europeo es el siguiente:

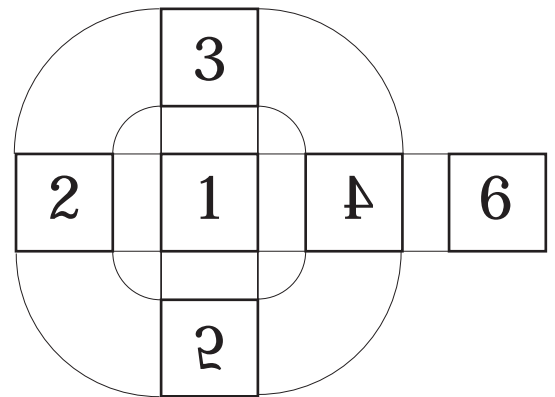
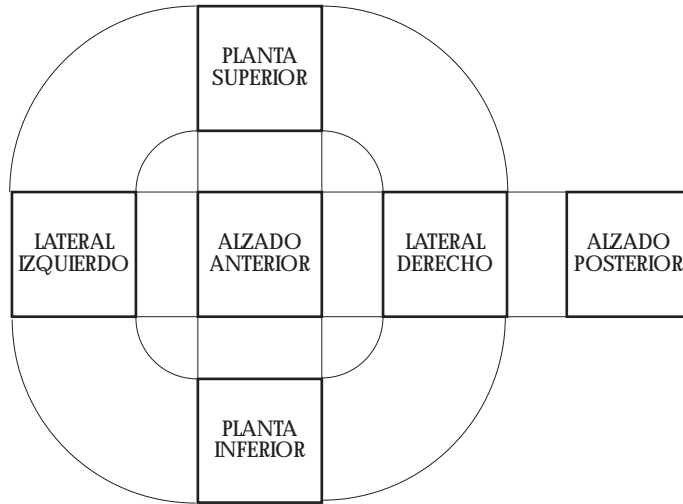
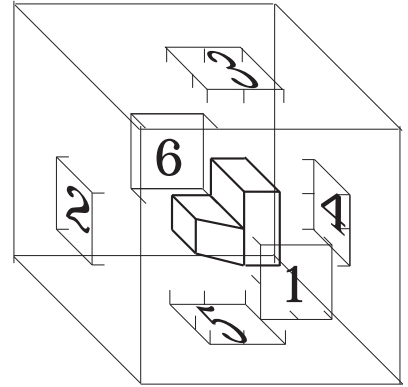
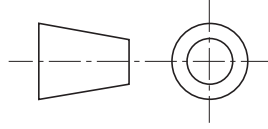

REPRESENTACIÓN DE LAS CARAS DE UN SÓLIDO Y SU DISPOSICIÓN EN EL PLANO EN SISTEMA AMERICANO.

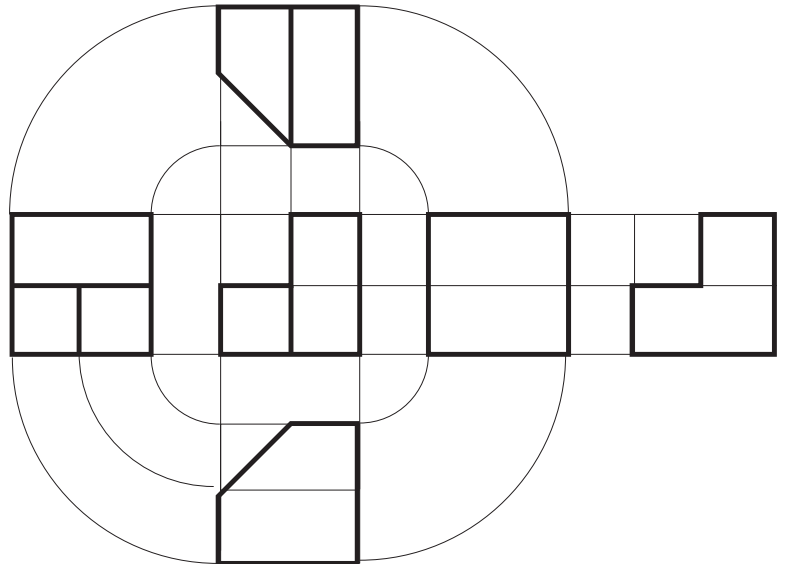
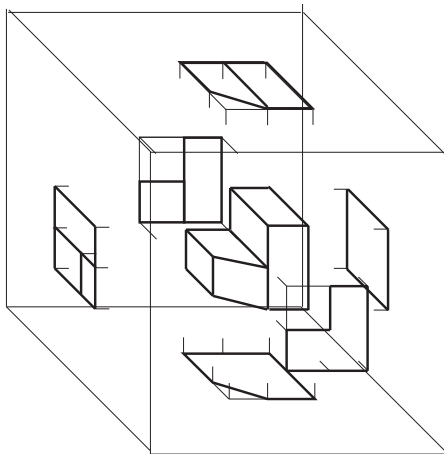

REGLAS PARA LA ELECCIÓN DE VISTAS:

- LAS VISTAS ELEGIDAS HAN DE PERMITIR INTERPRETAR LA PIEZA, QUE SE TRATA DE REPRESENTAR CON TOTAL PRECISIÓN Y SIN AMBIGUEDAD.
- SE REPRESENTARÁ EL MENOR NÚMERO DE VISTAS.
- SE ELIGE EL ALZADO DE FORMA QUE DE MEJOR IDEA DE LA FORMA DE LA PIEZA.
- SE ELIGIRÁN LAS VISTAS DE FORMA QUE PRODUZCA EL MENOR NÚMERO DE LÍNEAS OCULTAS.

V I S T A S E N S I S T E M A E U R O P E O

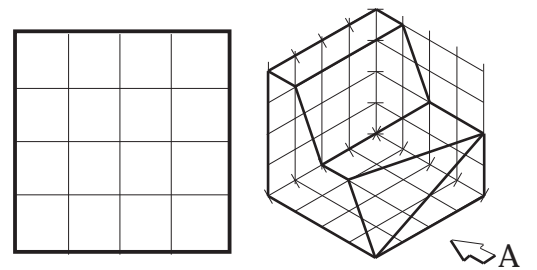
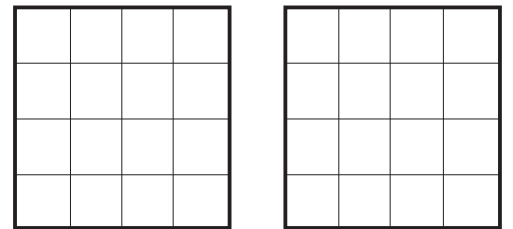
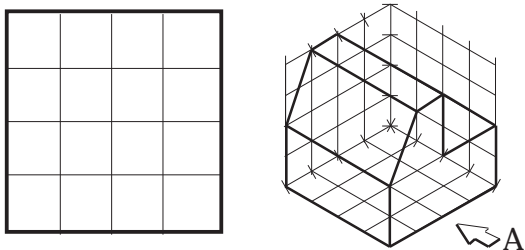
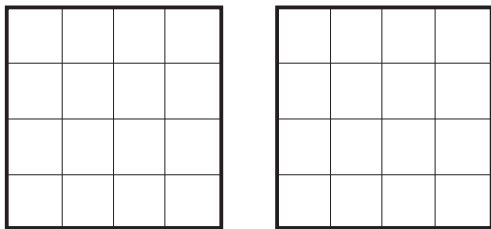
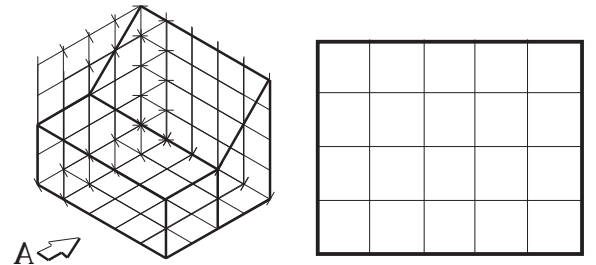
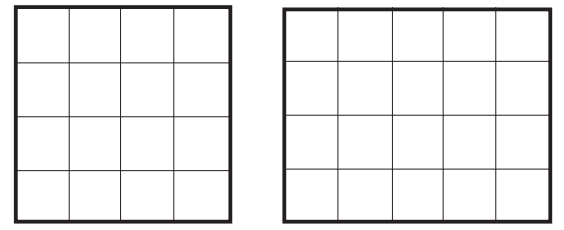
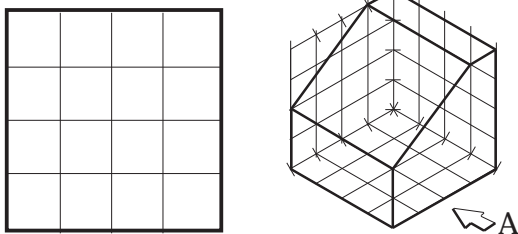
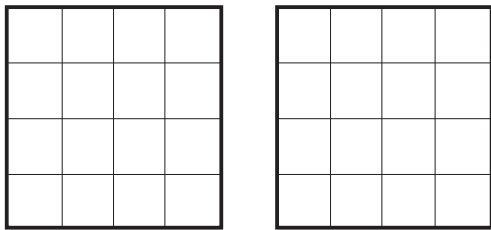
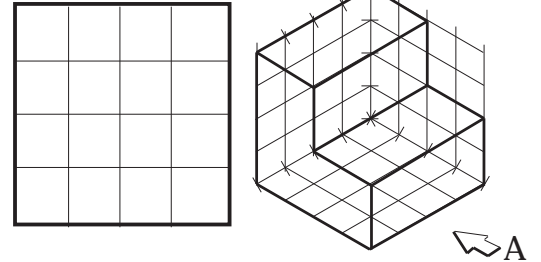
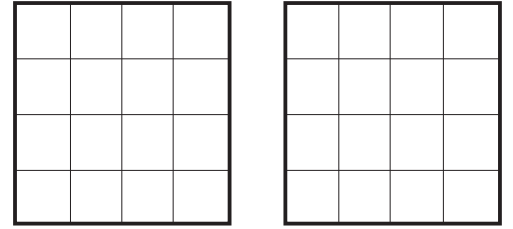
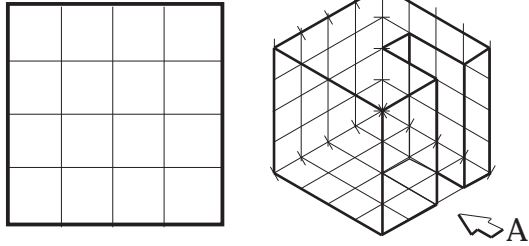
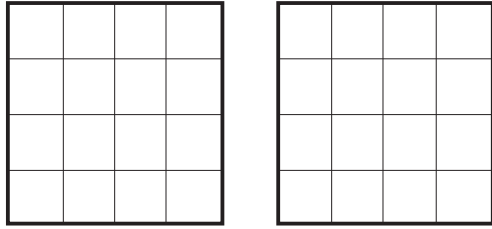

V I S T A S E N S I S T E M A E U R O P E O

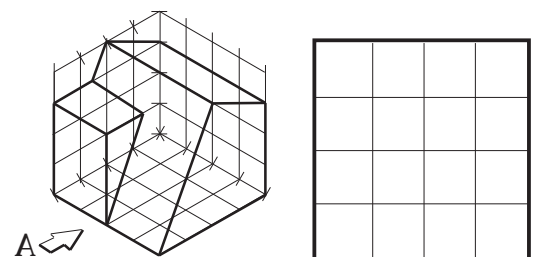
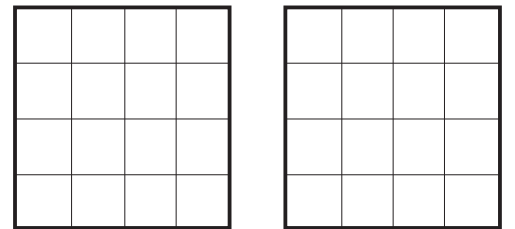
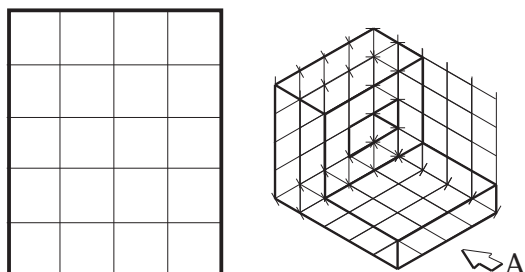
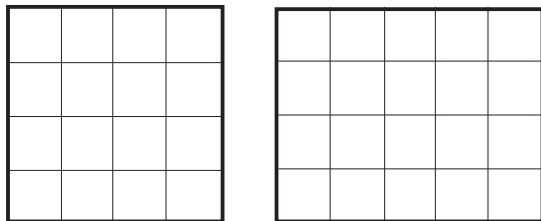
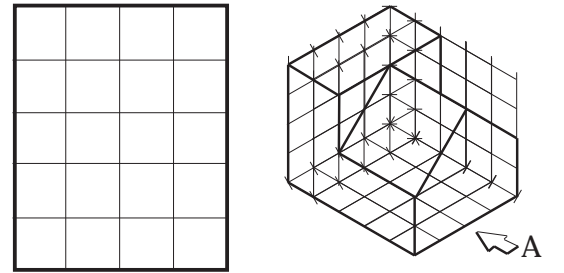
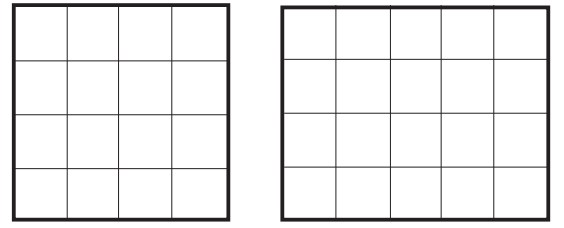
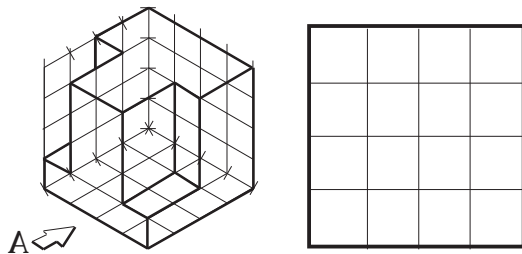
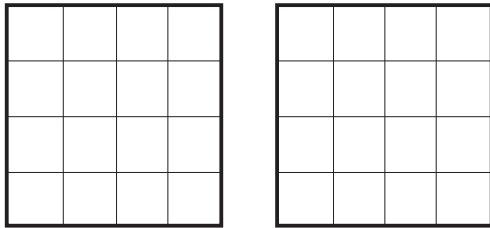
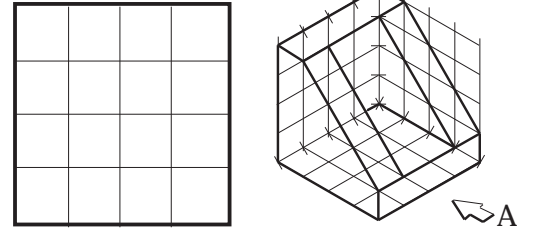
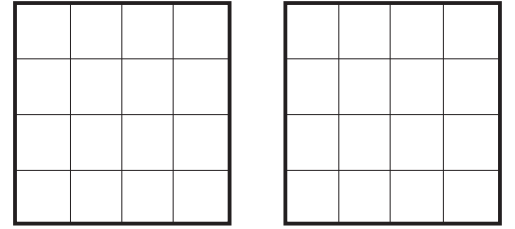
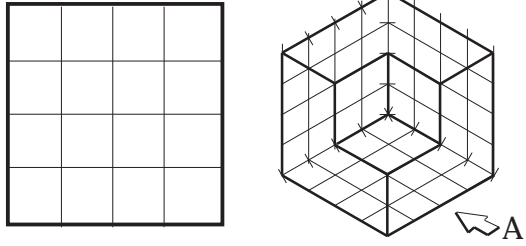
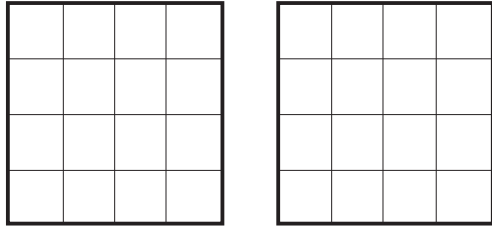

V I S T A S E N S I S T E M A E U R O P E O

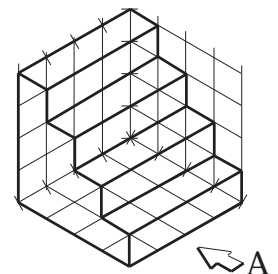
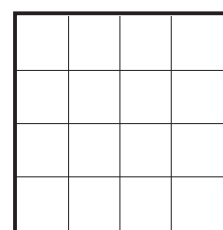
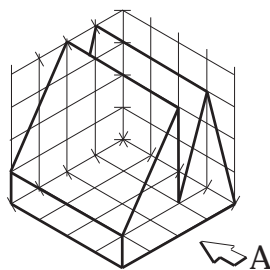
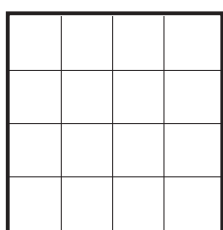
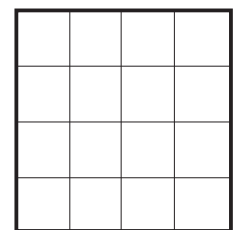
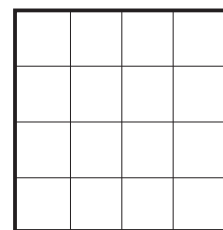
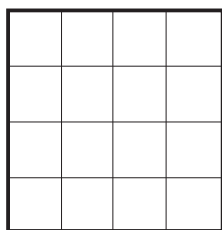
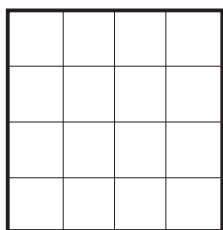
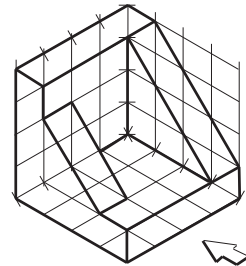
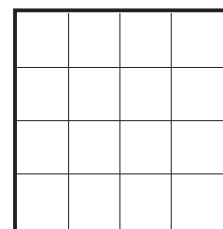
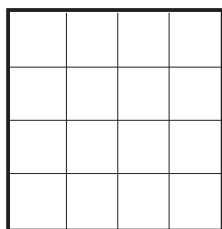
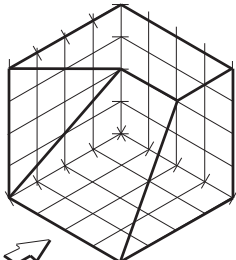
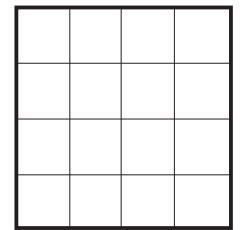
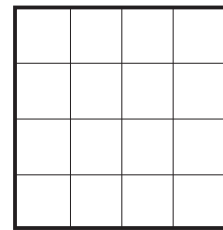
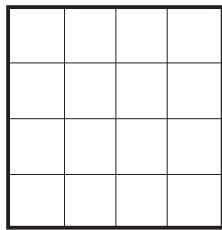
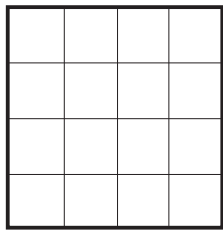
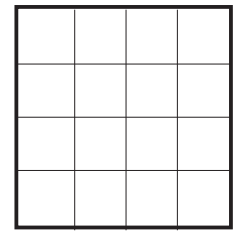
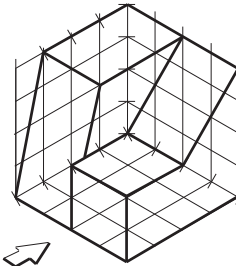
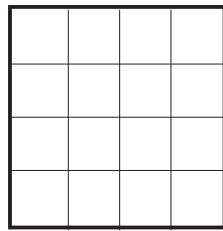
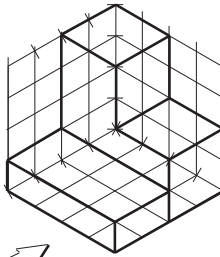
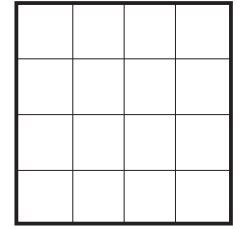
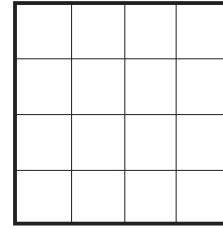
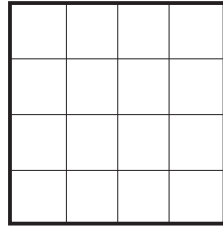
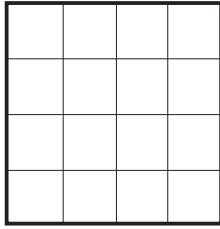

V I S T A S E N S I S T E M A E U R O P E O

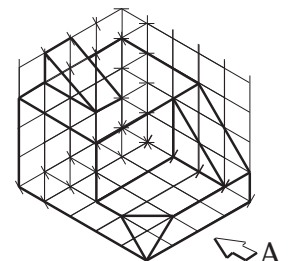
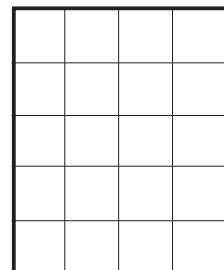
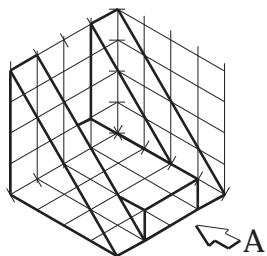
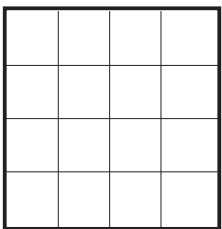
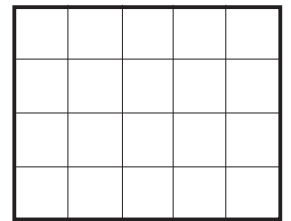
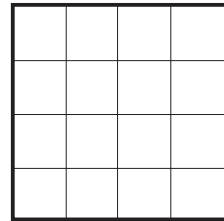
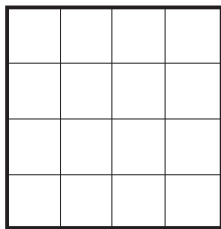
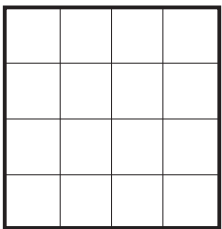
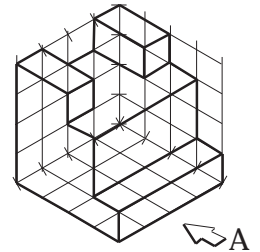
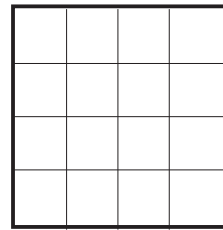
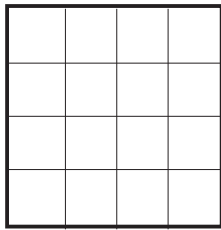
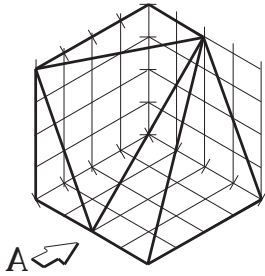
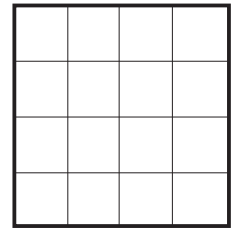
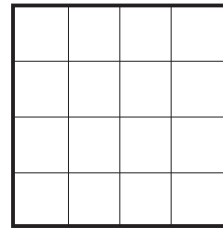
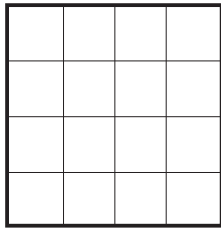
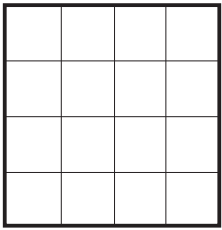
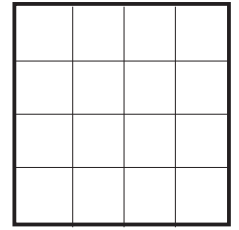
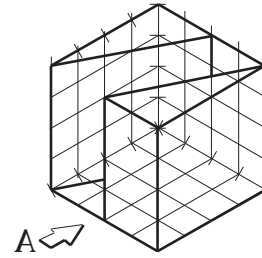
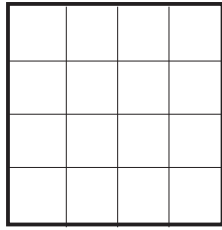
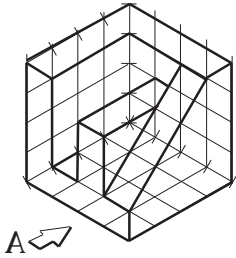
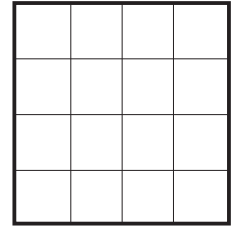
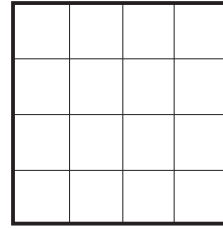
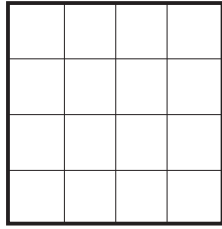
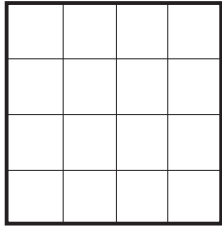

V I S T A S E N S I S T E M A E U R O P E O

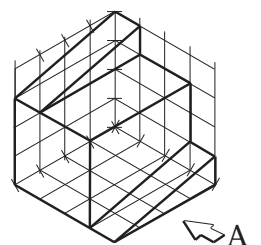
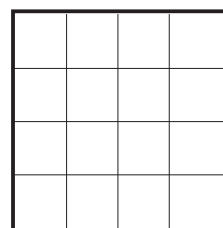
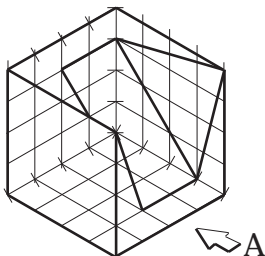
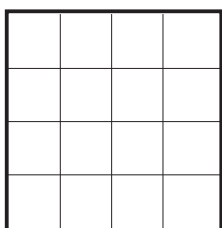
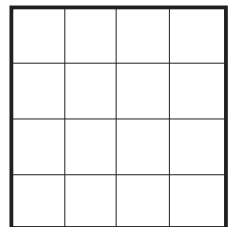
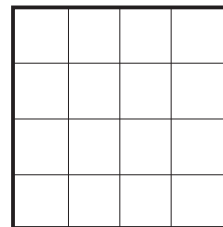
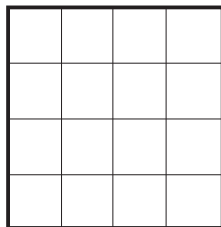
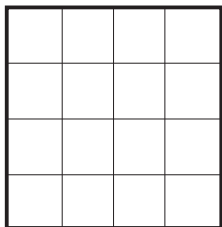
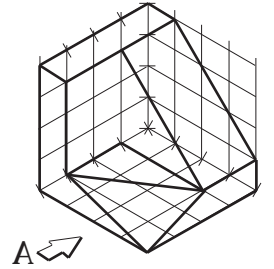
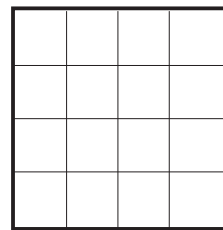
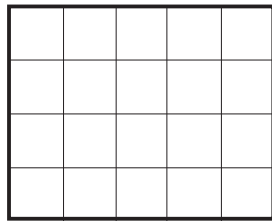
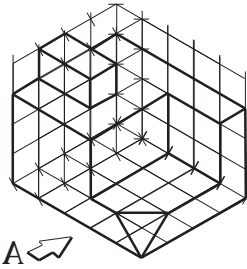
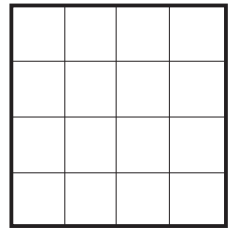
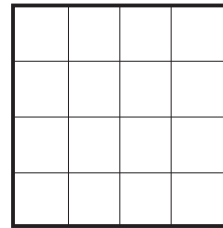
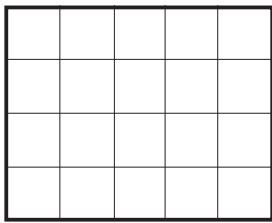
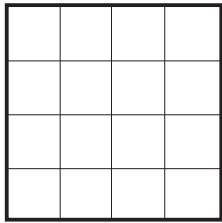
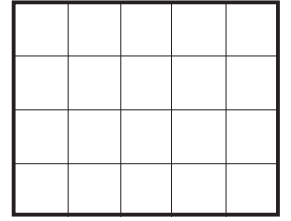
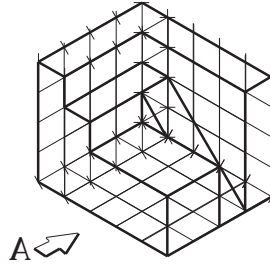
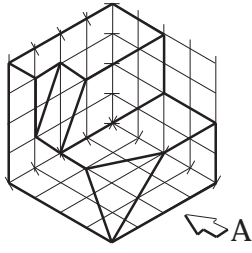
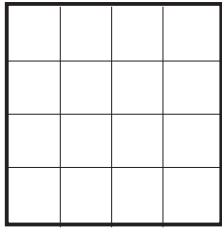
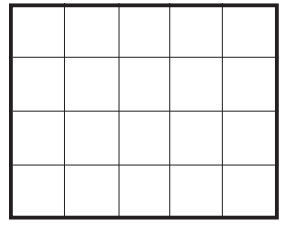
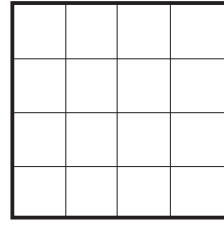
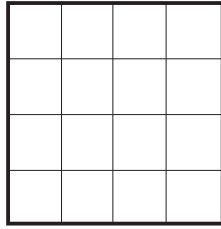
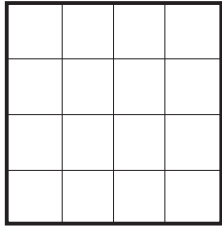

V I S T A S E N S I S T E M A E U R O P E O

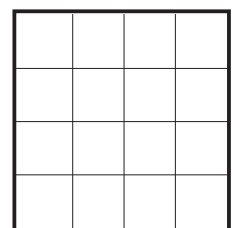
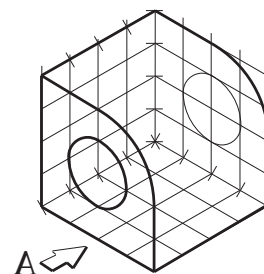
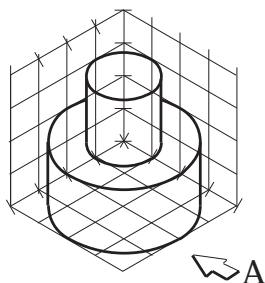
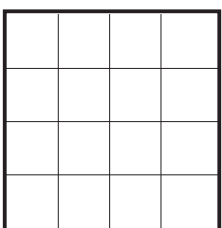
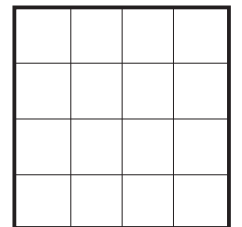
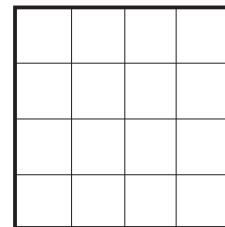
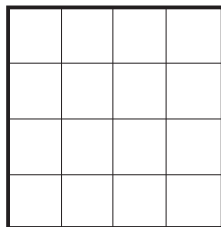
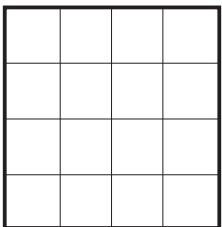
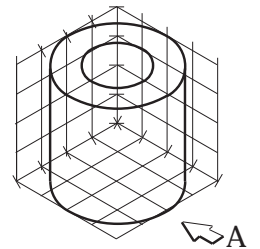
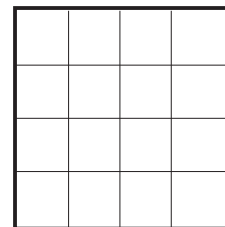
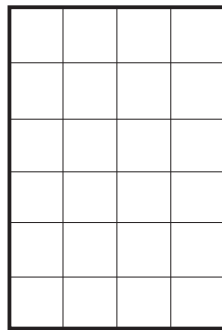
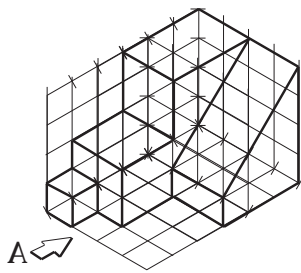
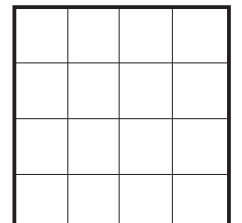
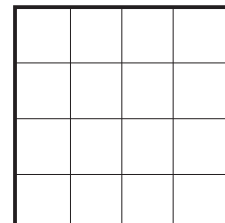
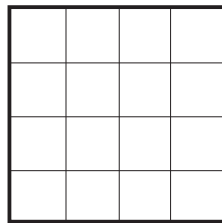
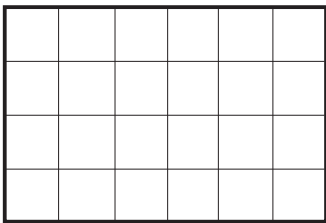
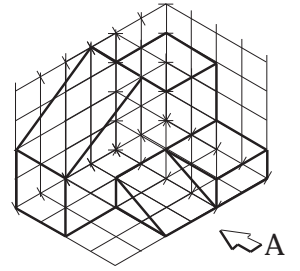
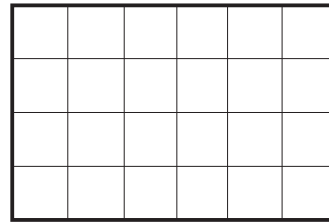
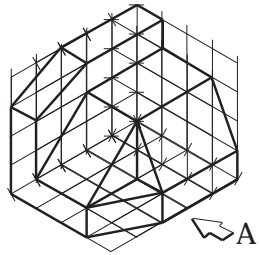
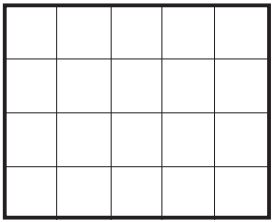
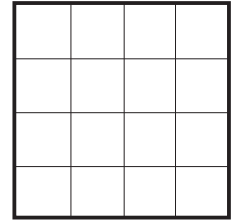
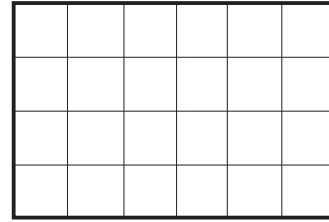
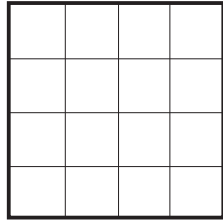
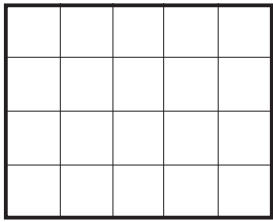

V I S T A S E N S I S T E M A E U R O P E O

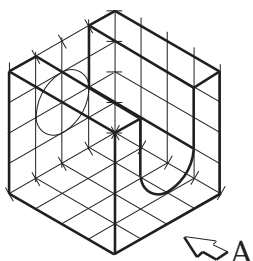
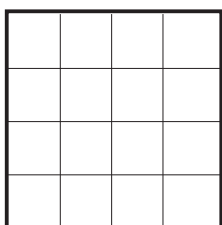
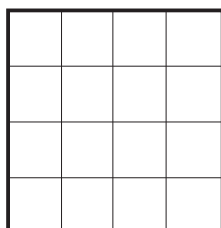
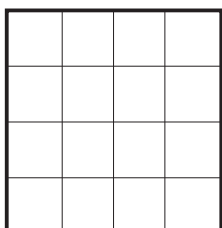
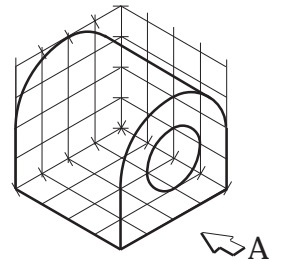
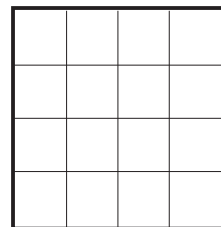
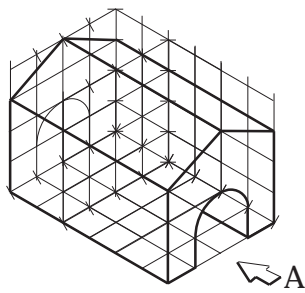
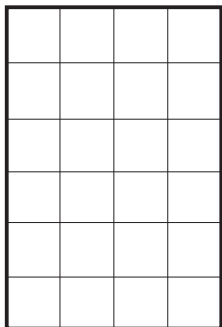
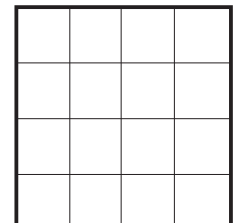
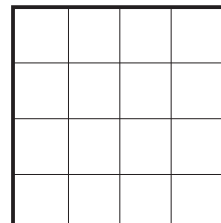
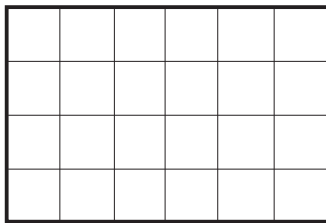
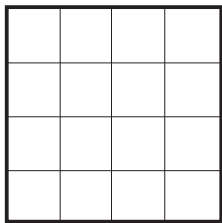
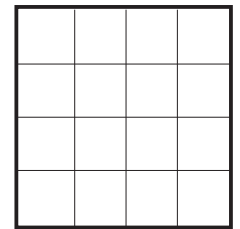
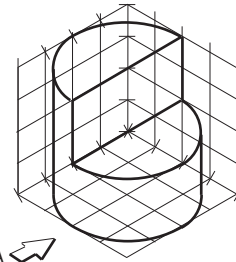
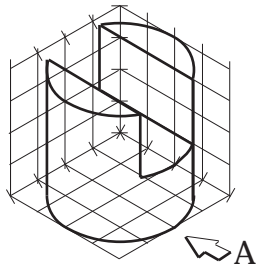
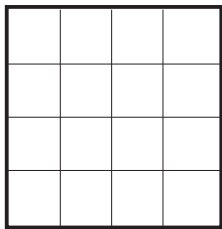
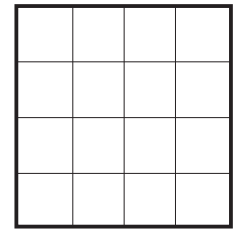
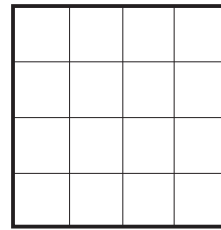
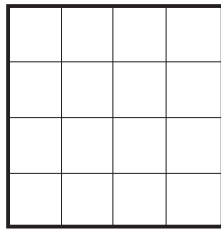
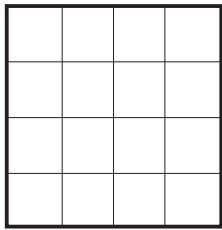

H A Z T U P R O P I A F I G U R A

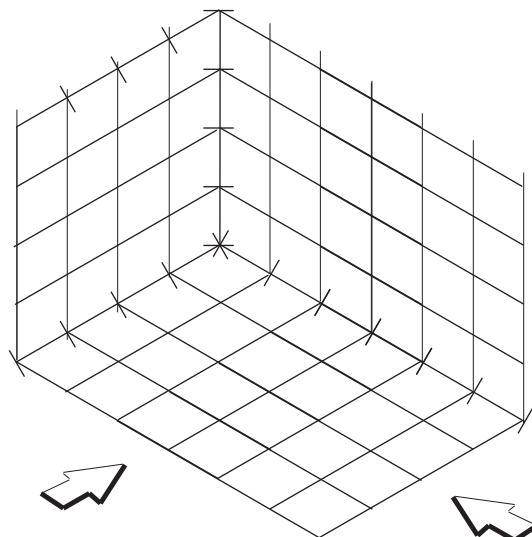
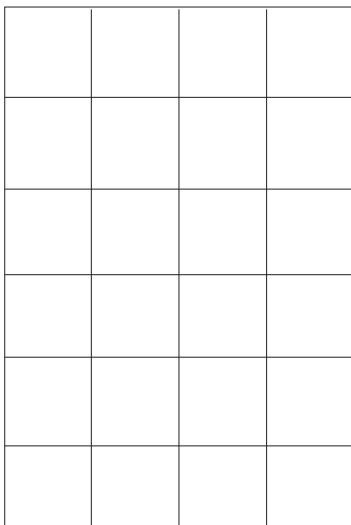
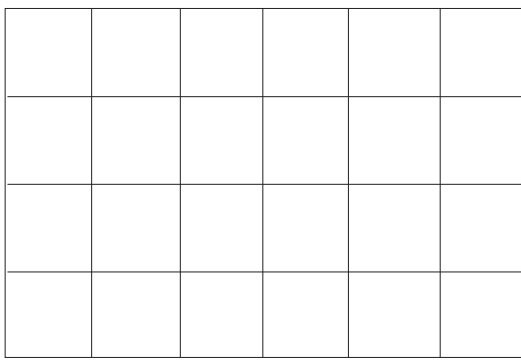
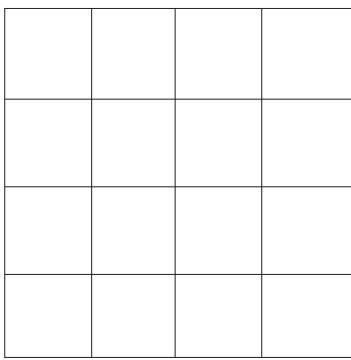
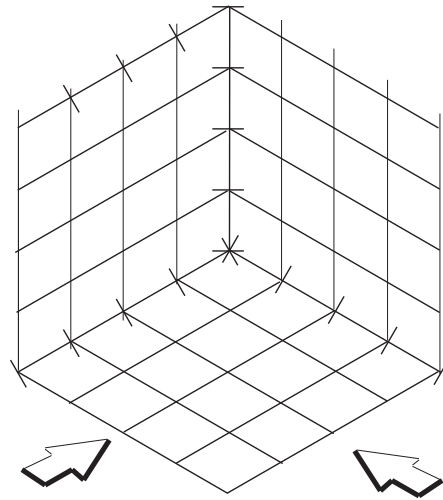
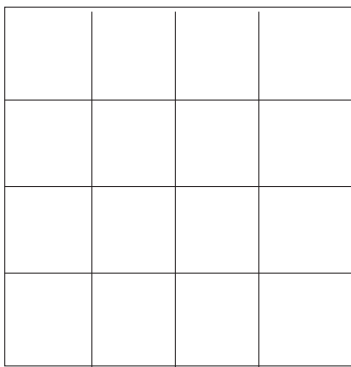
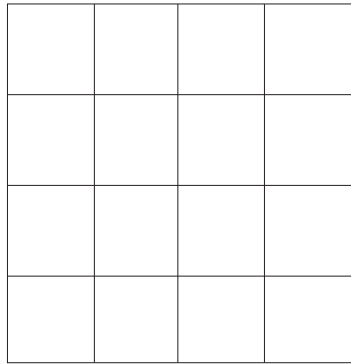
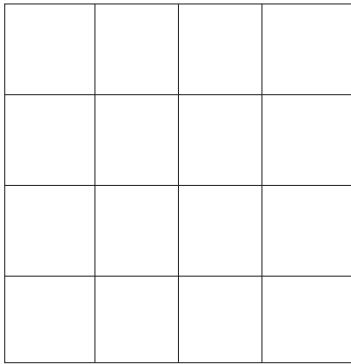

H A Z T U P R O P I A F I G U R A

